



 **CONCRETE CANVAS[®]**
Concrete on a Roll

INSTALLATION GUIDE: CULVERT LINING



The Queen's Awards
for Enterprise:
International Trade
2019



Board of Trade
Winner
2016



Winner
Technical Innovation Award



Innovation Award
ICE Wales Cymru Awards 2017



British Board of Agrément
Certified



Certified CPD
Provider



Corporate
Member



Proud Supporter of
Exporting is Great



RAIL



ROAD



MINING



PETROCHEM



AGRO



PUBLIC WORKS



UTILITIES



DEFENSE



DESIGN



SHELTER

1.0 General

Concrete Canvas® (CC) is the original Geosynthetic Cementitious Composite Mat (GCCM) and the first product to declare conformance to ASTM D8364 'Standard Specification for GCCMs'. It is a flexible, concrete filled geotextile that hardens on hydration to form a thin, durable and waterproof concrete layer. Essentially, it can be described as *Concrete on a Roll*™ and is used for a wide variety of applications including the rapid lining of drainage channels, providing slope protection, weed suppression, culvert repair and general concrete remediation.

This document provides general guidance procedures for the installation of CC for protecting the invert of corrugated metal culverts from surface wear in a manner that maximises safety, efficiency, and the physical integrity of the material and culvert. Note that CC is not to be used for stabilization, the culvert must be structurally sound. For concrete or masonry culvert protection please consult the [CCUSA Installation Guide - Remediation](#).

- This installation guidance should be read in conjunction with the construction drawings taking into account the designer's project specifications. Consult the [CCUSA Specification Guide: Watercourses](#) for detailed installation advice.
- The versatile nature of CC means that this document is not exhaustive and is intended for guidance purposes only. Exceptions to this guideline may be required to address site-specific conditions.
- The performance of the CC is wholly dependent on the quality of its design and installation. It is the installer's responsibility to adhere to these guidelines where applicable and to the project specification and construction drawings.

2.0 Equipment Required

- Sufficient CC to complete the project including allowance for edge fastenings and overlaps
- Suitable lifting equipment to dispense CC Bulk or Wide Rolls
- Safety mask and gloves
- Cutting equipment, utility knife or disc cutter
- Drill driver and suitable tech screws, through bolts, screw anchors or alternative approved method to join the CC layers
- Water supply
- See the [CCUSA Equipment List](#) for full details.
- For ordering, offloading and storage information, see the [CCUSA Logistics Guide](#) for full details.
- Dust hazard. Wear appropriate PPE. Consult the [CCUSA SDS](#) document.

3.0 Substrate Preparation

Divert water (if lining an existing culvert). Remove vegetation, soil, gravel and any debris from previous linings (such as loose bitumen coatings) to expose the corrugations in the culvert. High pressure jet washing is often used.

Non-structural damage to the culvert (e.g. voids or pitting created by rust or corrosion) must be filled with concrete, grout or compacted gravel depending on the designer requirements. Large bolts or protrusions that may cause the CC to snag should be smoothed out using suitable concrete or grout.

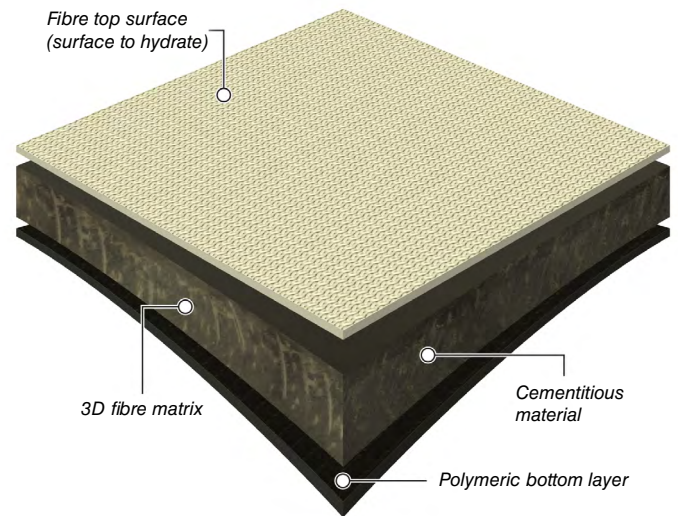

Typical CC cross section



Equipment required



Sandbagging and pumping to dry the culvert for install



Damage to culvert infilled with gravel and geotextile

If the CC will be terminated in anchor trenches outside the culvert, excavate the leading and trailing edge anchor trenches into the soil at the inlet and outlet. Anchor trench dimensions must be a minimum of 6in x 6in but may need to be increased to suit the designer's requirements.

Consult the construction drawings to verify if special subgrade preparation measures such as substrate drainage details are needed.

3.1 Filling of Corrugations

The designer must confirm whether the corrugations are to be filled as part of the CC lining solution. Filling the corrugations ensures the material is properly supported, providing optimum durability and resistance to dynamic loading. In some low flow, low impact applications, the culvert has been lined in CC without filling the corrugations. On these projects the working life of the culvert has been extended by 5-10 years.

If the designer confirms the corrugations are to be filled, this is typically carried out before installing the CC, by using a suitable rapid set, non-shrink grout. This method is often used when there is damage to the culvert that must be filled at the same time. Alternatively, if there is no significant damage to the culvert, the corrugations in the invert must be filled prior to placing the CC but the sides of the corrugations can be left unfilled until the CC has been hydrated and cured. Once cured the space between the CC and the side corrugations can be infilled using a suitable material, for example a cement grout or roofing tar (depending on environmental regulations). Additional intermediate fasteners may be required when filling behind cured CC to ensure the material does not lift from the culvert. Check the designer's requirements.

4.0 Deployment

It is recommended to begin at the downstream end of culvert and work upstream.

Culvert structures have limited access for heavy lifting equipment and for the majority of projects the CC is moved into position by hand. Batched Rolls of CC require a 2-4 person lift, but using Batched Rolls may be less economical if the culvert dimensions result in excessive wastage. It is often preferred to minimize wastage by cutting custom batched lengths on site from standard Bulk Rolls. The Bulk Rolls can be suspended outside of the culvert using roll stands, then unrolled and cut to the site-specific batched length as required before transporting into the culvert by hand or by trolley. When removing packaging make sure to note the Roll ID.

Unroll CC in the culvert to suit the specified layup (longitudinal or transverse layup as specified on the design drawings), ensuring the fibrous top surface faces upwards, with the PVC membrane in contact with the culvert. Avoid snagging the CC on bolts or any protrusions. It is important to relax the material to relieve any tension generated in deployment. This can be achieved by lifting the CC layer by hand and repositioning. The installer can adjust the material to remove any wrinkles and ensure the CC conforms to the culvert when hand repositioning.



Power hose used to remove coatings and debris



Filling of corrugations covering damage

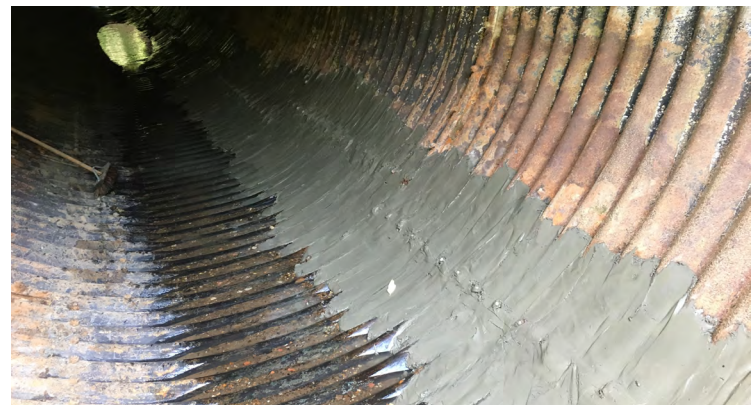

Smoothing over protrusions using grout



Filling of corrugations

It is not common for CC to be installed above the springline (or maximum span for non-circular culverts). If the design requires the CC to extend beyond the vertical, please contact Concrete Canvas Ltd for installation advice.

Personnel must not wear damaging shoes and avoid walking on the CC surface particularly if corrugations will be filled after hydration. The surface can be protected by using timber boards to prevent boots from creating depressions in the material.

Ensure the trailing edge of the first layer of CC is either suitably terminated into existing infrastructure and fixed to prevent water ingress, or tucked into an anchor trench which is backfilled to prevent scour beneath CC. See Section 6.2.

When positioning subsequent layers, ensure there is at least a 4in overlap in the direction of water flow (shingled like roof tiles) and that the material layers are in intimate contact with each other.

5.0 Jointing

Verify the specified joint method to be installed.

5.1 For anchor fastening / anchor fastening and sealed overlap joints:

- Fold back top layer and hydrate the material under the overlapped sections of the CC. Once hydrated, the material remains workable for 1 to 2 hours.
- If applying a CC approved sealant, apply a 0.3in diameter continuous bead along the line of where the anchor fasteners will be positioned (e.g. for a 4in overlap with 1.25in from the edge of the top layer, the sealant bead needs to be 2.75in from the edge of the bottom layer)
- Anchor fasteners must be self tapping tech screws, through-bolts or screw anchors with a minimum head or washer diameter of 0.6in, or as specified by the designer. Shot fired nails are not recommended. The designer should specify the appropriate type of fastener to use, as stainless steel fasteners provide the greatest durability but their compatibility with the steel culvert structure should be assessed in order to prevent bi-metallic corrosion.
- The anchor fasteners should be secured through the metal culvert at a maximum spacing of 20in (12in for warmer climates) and 1.25-2in from the edge of the CC.
- Additional fasteners may also be required at discrete locations to prevent opening of the overlapped material and ensure intimate contact with the culvert, particularly around tight radii. This is a judgment call that needs to be made on site.
- It is possible to use anchor fasteners for jointing as 'intermediate fasteners', providing they meet certain design requirements. See section 7.0.

5.2 For Thermal Bond joints:

- Ensure CC remains dry and unhydrated before jointing
- Follow the [CCUSA User Guide: Thermal Bonding](#) for the correct procedure.



On site bespoke batching from a CC Bulk Roll



Bespoke batched CC transported into culvert



Batched material transported using a trolley

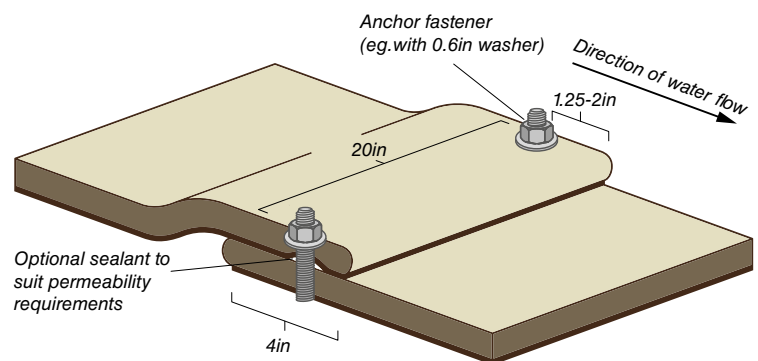

Typical jointing arrangement

- Overlaps jointed by Thermal Bonding do not typically require anchor fasteners, unless they are needed as ‘intermediate fasteners’, see section 7.0.
- Note that the CC and the working area must be dry for Thermal Bonding to be successful.

Ensure there is no wrinkling at the joint and both layers are in contact with each other. Care shall be taken during installation to avoid damage occurring to the CC. Should the CC be damaged during installation and before hydration, the layer should be removed and replaced.

6.0 Perimeter Edge Fastening

It is essential that all exposed (i.e. unjointed) edges of the CC should be secured during the installation to prevent water infiltration underneath the CC which may cause movement and uplift of the CC material.

6.1 When fastening to the sides of the metal culvert:

- Consult the construction drawings for the anchor fastening specifications and fastening spacings. It is important to use the fasteners and washer diameter/clamping bar specified by the designer to ensure the edge fastening has the required design strength to prevent pull out/shear. Consult the [CCUSA Specification Guide: Watercourses](#) for advice.
- Position the CC against the culvert and drill a pilot hole through the CC and the metal culvert before inserting the anchor fastener (if using Tech screws, they should not require pre drilling). Do not secure into the infill to the corrugations alone.
- Use appropriate sealant/gasket and washers/clamping bar as specified by the designer to reduce water infiltration.

6.2 Leading / Trailing Edges:

It is essential to ensure the leading and trailing edges of the CC are either suitably terminated outside of the culvert into existing infrastructure and fastened to prevent water ingress (e.g. using stainless steel clamping bar and gasket), or tucked into an anchor trench which is backfilled to prevent scour beneath CC.

When fastening to Soil (i.e. using anchor trenches):

- Position the CC over the end of the culvert and into the anchor trench.
- Fix the CC in the anchor trench by inserting pegs through each overlap or at a maximum of 6.5ft intervals for longitudinal installations or at 3ft maximum spacings for transverse installations.
- The CC should be hydrated before backfilling with non-erodible fill. This may be soil or concrete depending on the design. Consult the construction drawings.

When fastening to Concrete / Masonry / Rock:

- Consult the construction drawings for the anchor fastening specifications and fastener spacings. It is important to use the fasteners and washer diameter / clamping bar specified by the designer to ensure the edge fastening has the required design strength to prevent pull out/shear. Consult



CC perimeter edge secured with clamping bar



Perimeter edge secured with anchor fasteners and washers



Timber secured to provide a cutting edge guide for a neat finish



Grout applied to edges to prevent water ingress

the [CCUSA Specification Guide: Watercourses](#) for advice.

- Position the CC against the structure and drill a pilot hole through the CC and the structure before inserting the anchor fastener.
- Use appropriate sealant / gasket and washers / clamping bar as specified by the designer to ensure a strong, watertight seal.

In some instances, the CC can be folded around the metal culvert structure, before the headwall is formed in concrete or blockwork, capturing the CC. Consult the construction drawings.

7.0 Intermediate Fastening

Additional intermediate fastenings may be necessary to profile CC to ensure it conforms to the underlying surface and remove voids (especially when filling the corrugations after CC installation), or to resist the following load conditions:

- Hydraulic Shear Loads: e.g. lining watercourse structures with an incline $>10\%$
- When overlaps are jointed with a thermal bond, additional intermediate fastenings may be required in line with Warmer Climate Detailing: e.g. where CC profile lengths exceed 10ft, a fastening is needed at a maximum spacing of every 10ft along the profile, through each overlap joint.

The intermediate fastener type, performance requirements and installation locations should be specified by the designer to suit the anticipated load conditions.

8.0 Custom Detailing

Consult the construction drawings for custom detailing such as baffling, accommodating pipe penetrations, etc. Concrete Canvas Ltd can provide advice on unusual site specific details.

9.0 Hydration

If necessary, the Installer must place temporary ballast, such as sandbags, on top of the laid CC prior to hydration to ensure that it lies flat to the culvert.

After fastening and jointing, the surface of the CC can be brushed clean to remove marks and debris before spraying with water to hydrate. Diverted water can be used for hydration, but should be pumped and sprayed.

Spray the fiber surface multiple times until the CC is fully saturated. The wet CC will first darken and then become lighter as it absorbs the water.

Do not spray high pressure water directly onto the CC as this may cause washout of the cementitious fill in the material.

CC can be hydrated using fresh water or salt water, it is not possible to over hydrate CC and it will set underwater.

A minimum volume of water equal to 40% of the material weight is required. For example, CCT2™ requires 1.5gal per 10ft².

To check proper hydration, the CC should feel wet to the touch several minutes after hydration. Press your thumb into the CC and release. If water is present in the depression in the CC, it has been sufficiently hydrated. If no water is observed, then more water must be applied.



CC edge fastening to masonry using screw anchors



Trailing edge secured to concrete apron



Leading edge buried in anchor trench

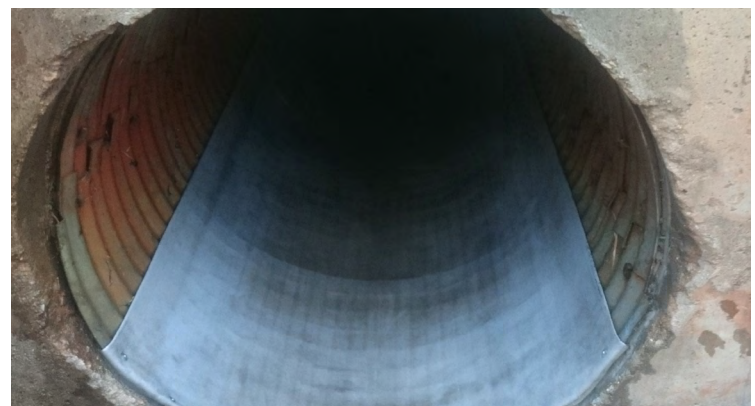

Leading edge folded back around culvert before grouting smooth

Specific hydration methods are required in drying conditions (installing in high air temperatures (>22°C/71°F), wind (>12km/h/ 7.45mph), strong direct sunlight or low humidity (<70%)) and in low temperature conditions. Please consult the [CCUSA User Guide: Hydration](#) which is also attached to all CC Bulk rolls.

10.0 Setting

There is a working time of 1-2 hours after hydration. Backfill any leading or trailing edge anchor trenches with non-erodible fill as specified in the construction drawings.

CC hardens to strength in 24 hours and is then ready for use. Allow the CC to cure for at least 48 hours before applying any post installation surface treatments such as jet washing or painting.

11.0 Installation Sequence

Planning of CC installations is necessary to ensure tools and materials (e.g. hydration water) are available when required.

Only install what can be fully jointed, fixed and hydrated before the end of construction day to minimize any adverse effect on the installation and/or performance capabilities of the product.

If installation continues the following working day, protect the edge of the last layer of CC overnight with waterproof sheeting to enable jointing when returning to work.

An example install sequence is described below:

- Morning - Deploy CC panels and secure along the perimeter edges.
- Early afternoon - Jointing of panels (e.g. hydrate underlap, apply sealant, anchor joints), install intermediate fastenings.
- Late afternoon - Hydration (following drying/low temperature condition guidance as required).

12.0 Maintenance and Repair

For the majority of projects, CC does not require cleaning or maintenance unless structures such as silt traps are installed. If required, consult the [CC User Guide: Cleaning and Maintenance](#). If damage is found during a periodic inspection, contact [Concrete Canvas USA](#) for repair advice.

Concrete Canvas Ltd and its Sales Partner distribution network can provide manufacturers recommendations for specific projects, but before installing all details must be agreed and adopted by the engineer under their design responsibility.



Hydration



Completed project - Cooks Bridge



Completed project - Halfway Bridge

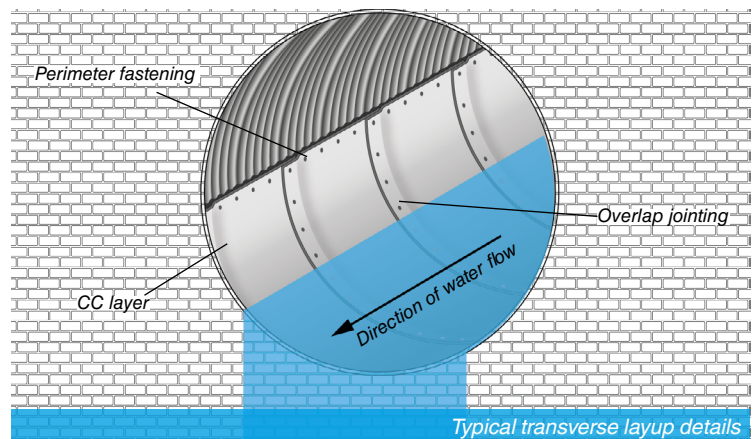

Typical transverse layup details