

StormTech[®] Installation Guide

MC-3500 & MC-4500 Chamber



StormTech
Installation Video

Required Materials and Equipment List

- Acceptable fill materials per Table 1
- ADS Plus and non-woven geotextile fabrics
- StormTech solid end caps, pre-cored and pre-fabricated end caps
- StormTech chambers, manifolds and fittings

Note: MC-3500 chamber pallets are 77" x 90" (2.0 m x 2.3 m) and weigh about 2010 lbs. (912 kg) and MC-4500 pallets are 100" x 52" (2.5 m x 1.3 m) and weigh about 840 lbs. (381 kg). Unloading chambers requires 72" (1.8 m) (min.) forks and/or tie downs (straps, chains, etc).

Important Notes:

- This installation guide provides the minimum requirements for proper installation of chambers. Nonadherence to this guide may result in damage to chambers during installation. Replacement of damaged chambers during or after backfilling is costly and very time consuming. It is recommended that all installers are familiar with this guide, and that the contractor inspects the chambers for distortion, damage and joint integrity as work progresses.
- Use of a dozer to push embedment stone between the rows of chambers may cause damage to chambers and is not an acceptable backfill method. Any chambers damaged by using the "dump and push" method are not covered under the StormTech standard warranty.
- Care should be taken in the handling of chambers and end caps. End caps must be stored standing upright. Avoid dropping, prying or excessive force on chambers during removal from pallet and initial placement.

Requirements for System Installation



Excavate bed and prepare subgrade per engineer's plans. Plans and specifications should include Best Management Practices (BMPs) to deter contamination of open pits during construction.



Place non-woven geotextile over prepared soils and up excavation walls.



Place clean, crushed, angular stone foundation 9" (230 mm) min. Install underdrains if required. Compact to achieve a flat surface.

Manifold, Scour Fabric and Chamber Assembly



Install manifolds and lay out ADS PLUS fabric at inlet rows [min. 17.5 ft (5.33 m)] at each inlet end cap. Place a continuous piece (no seams) along entire length of Isolator® PLUS Row(s).



Align the first chamber and end cap of each row with inlet pipes. Contractor may choose to postpone stone placement around end chambers and leave ends of rows open for easy inspection of chambers during the backfill process.



Continue installing chambers by overlapping chamber end corrugations. Chamber joints are labeled "Lower Joint - Overlap Here" and "Build this direction - Upper Joint". Be sure that the chamber placement does not exceed the reach of the construction equipment used to place the stone. Maintain minimum 6" (150 mm) spacing between MC-3500 rows and 9" (230 mm) spacing between MC-4500 rows.



Place a continuous layer of ADS PLUS fabric between the foundation stone and the Isolator Row PLUS chambers, making sure the fabric lays flat and extends the entire width of the chamber feet. When used on an Isolator Row PLUS, a 24" FLAMP (flared end ramp) is attached to the inside of the inlet pipe with a provided threaded rod and bolt. The FLAMP then lays on top of the ADS PLUS fabric.

Manifold Insertion

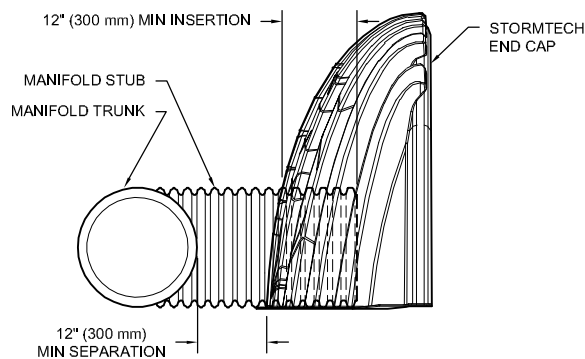

NOTE: MANIFOLD STUB MUST BE LAID HORIZONTAL FOR A PROPER FIT IN END CAP OPENING.

Insert inlet and outlet manifolds a minimum 12" (300 mm) into chamber end caps. Manifold header should be a minimum 12" (300 mm) from base of end cap.

StormTech Isolator Row Plus Detail

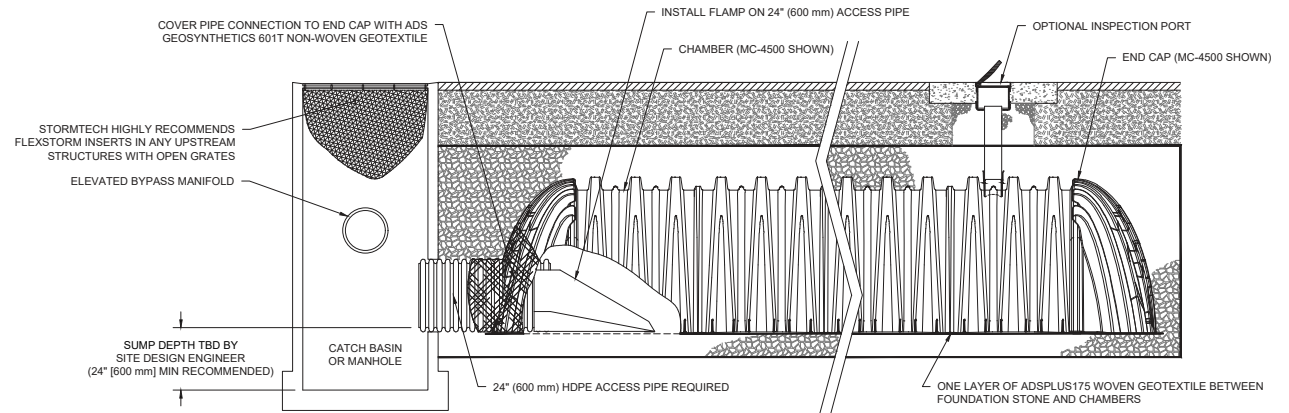

Initial Anchoring of Chambers – Embedment Stone



Initial embedment shall be spotted along the centerline of the chamber evenly anchoring the lower portion of the chamber. This is best accomplished with a stone conveyor or excavator reaching along the row.

No equipment shall be operated on the bed at this stage of the installation. Excavators must be located off the bed. Dump trucks shall not dump stone directly on to the bed. Dozers or loaders are not allowed on the bed at this time.

Backfill of Chambers – Embedment Stone

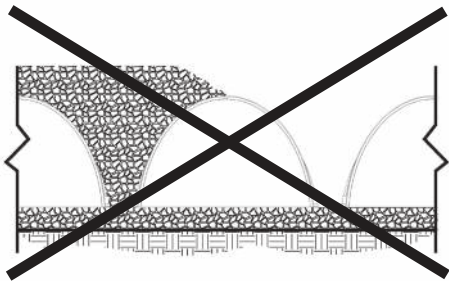

Uneven Backfill

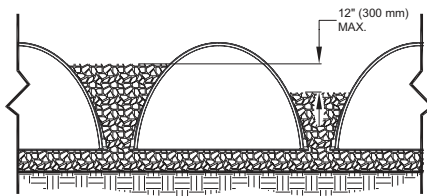

Even Backfill

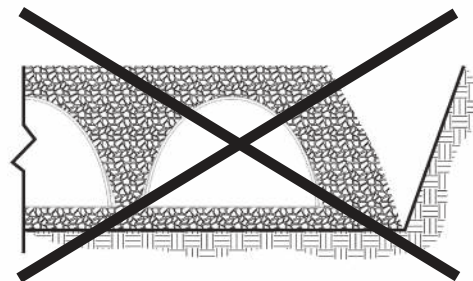

Perimeter Not Backfilled

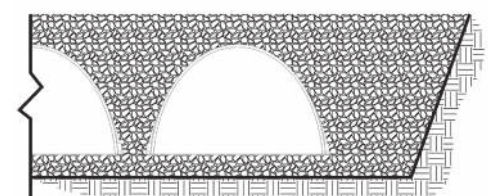

Perimeter Fully Backfilled

Backfill chambers evenly. Stone column height should never differ by more than 12" (300 mm) between adjacent chamber rows or between chamber rows and perimeter.

Perimeter stone must be brought up evenly with chamber rows. Perimeter must be fully backfilled, with stone extended horizontally to the excavation wall.

Backfill of Chambers – Embedment Stone and Cover Stone



Continue evenly backfilling between rows and around perimeter until embedment stone reaches tops of chambers and a minimum 12" (300 mm) of cover stone is in place. Perimeter stone must extend horizontally to the excavation wall for both straight or sloped sidewalls. The recommended backfill methods are with a stone conveyor outside of the bed or build as you go with an excavator inside the bed reaching along the rows. Backfilling while assembling chambers rows as shown in the picture will help to ensure that equipment reach is not exceeded.

Only after chambers have been backfilled to top of chamber and with a minimum 12" (300 mm) of cover stone on top of chambers can skid loaders and small LGP dozers be used to final grade cover stone and backfill material in accordance with ground pressure limits in Table 2. Equipment must push material parallel to rows only. Never push perpendicular to rows. StormTech recommends the contractor inspect chamber rows before placing final backfill. Any chambers damaged by construction equipment shall be removed and replaced.

Final Backfill of Chambers – Fill Material



Install non-woven geotextile over stone. Geotextile must overlap 24" (600 mm) where edges meet. Compact at 24" (600 mm) of fill. Roller travel parallel with rows.

Inserta Tee Detail

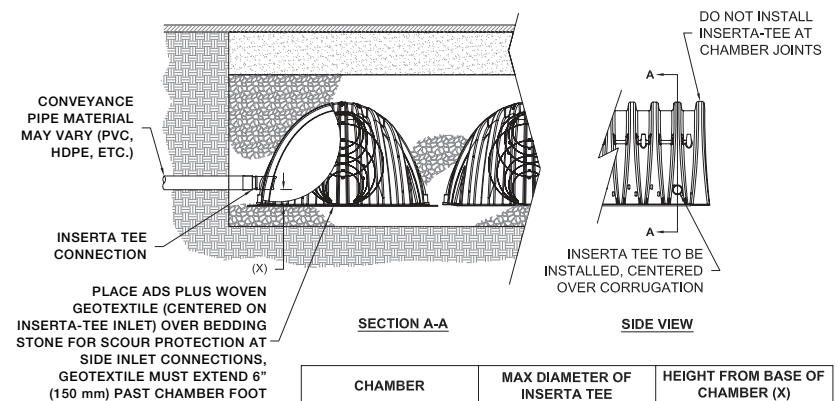

NOTE:
PART NUMBERS WILL VARY BASED ON INLET PIPE MATERIALS. CONTACT STORMTECH FOR MORE INFORMATION.

CHAMBER	MAX DIAMETER OF INSERTA TEE	HEIGHT FROM BASE OF CHAMBER (X)
MC-3500	12" (250 mm)	6" (150 mm)
MC-4500	12" (250 mm)	8" (200 mm)

INSERTA TEE FITTINGS AVAILABLE FOR SDR 26, SDR 35, SCH 40 IPS GASKETED & SOLVENT WELD, N-12, HP STORM, C-900 OR DUCTILE IRON

Table 1- Acceptable Fill Materials

Material Location	Description	AASHTO M43 Designation ¹	Compaction/Density Requirement
D Final Fill: Fill Material for layer 'D' starts from the top of the 'C' layer to the bottom of flexible pavement or unpaved finished grade above. Note that the pavement subbase may be part of the 'D' layer.	Any soil/rock materials, native soils or per engineer's plans. Check plans for pavement subgrade requirements.	N/A	Prepare per site design engineer's plans. Paved installations may have stringent material and preparation requirements.
C Initial Fill: Fill Material for layer 'C' starts from the top of the embedment stone ('B' layer) to 24" (600 mm) above the top of the chamber. Note that pavement subbase may be part of the 'C' layer.	Granular well-graded soil/aggregate mixtures, <35% fines or processed aggregate. Most pavement subbase materials can be used in lieu of this layer.	AASHTO M145 ¹ A-1, A-2-4, A-3 or AASHTO M43 ¹ 3, 357, 4, 467, 5, 56, 57, 6, 67, 68, 7, 78, 8, 89, 9, 10	Begin compaction after min. 24" (600 mm) of material over the chambers is reached. Compact additional layers in 12" (300 mm) max. lifts to a min. 95% Proctor density for well-graded material and 95% relative density for processed aggregate materials.
B Embedment Stone: Fill the surrounding chambers from the foundation stone ('A' layer) to the 'C' layer above.	Clean, crushed, angular stone	AASHTO M43 ¹ 3, 4	No compaction required.
A Foundation Stone: Fill below chambers from the subgrade up to the foot (bottom) of the chamber.	Clean, crushed, angular stone,	AASHTO M43 ¹ 3, 4	Place and compact in 9" (230 mm) max lifts using two full coverages with a vibratory compactor. ^{2,3}

Figure 1- Inspection Port Detail

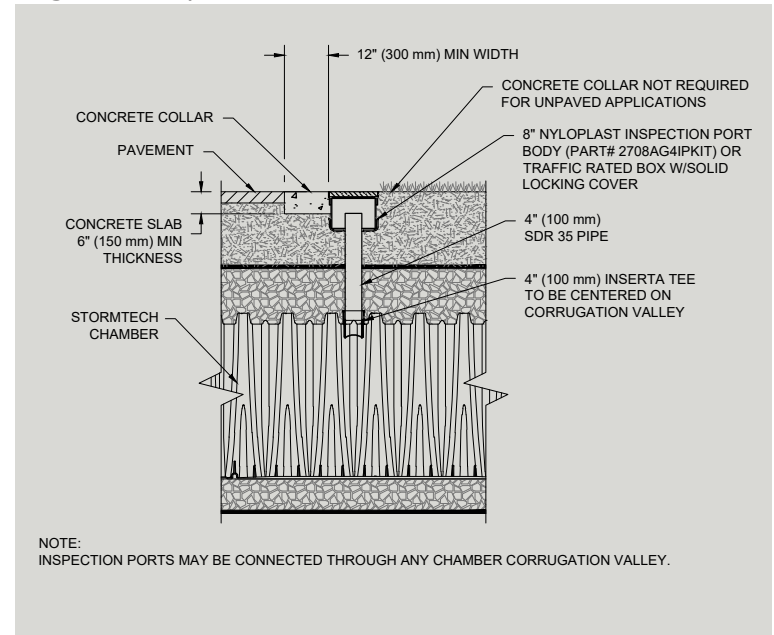

Please Note:

1. The listed AASHTO designations are for gradations only. The stone must also be clean, crushed, angular. For example, a specification for #4 stone would state: "clean, crushed, angular no. 4 (AASHTO M43) stone".
2. StormTech compaction requirements are met for 'A' location materials when placed and compacted in 9" (230 mm) (max) lifts using two full coverages with a vibratory compactor.
3. Where infiltration surfaces may be comprised by compaction, for standard installations and standard design load conditions, a flat surface may be achieved by raking or dragging without compaction equipment. For special load designs, contact StormTech for compaction requirements.

Figure 2 - Fill Material Locations

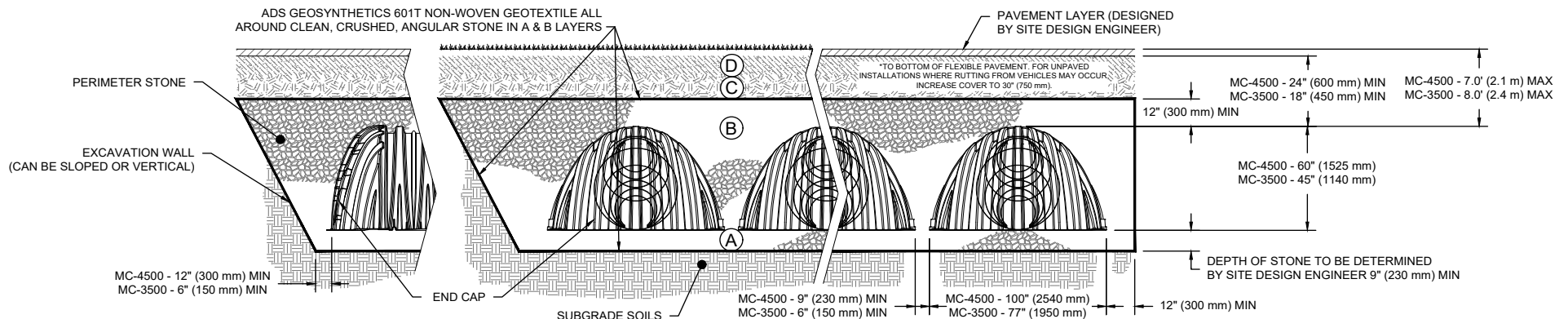

Notes:

- 36" (900 mm) of stabilized cover materials over the chambers is recommended during the construction phase if general construction activities, such as full dump truck travel and dumping, are to occur over the bed.
- During paving operations, dump truck axle loads on 18" (450mm) of cover for MC-3500s may be necessary. Precautions should be taken to avoid rutting of the road base layer, to ensure that compaction requirements have been met, and that a minimum of 18" (450mm) of cover for MC-3500s exists over the chambers. Contact StormTech for additional guidance on allowable axle loads during paving.
- Ground pressure for track dozers is the vehicle operating weight divided by total ground contact area for both tracks. Excavators will exert higher ground pressures based on loaded bucket weight and boom extension.
- Mini-excavators (<8,000lbs/3,628 kg) can be used with at least 12" (300 mm) of stone over the chambers and are limited by the maximum ground pressures in Table 2 based on a full bucket at maximum boom extension.
- StormTech does not require compaction of initial fill at 18" (450 mm) of cover. However, requirements by others for 6" (150 mm) lifts may necessitate the use of small compactors at 18" (450 mm) of cover.
- Storage of materials such as construction materials, equipment, spoils, etc. should not be located over the StormTech system. The use of equipment over the StormTech system not covered in Table 2 (ex. soil mixing equipment, cranes, etc) is limited. Please contact StormTech for more information.
- Allowable track loads based on vehicle travel only. Excavators shall not operate on chamber beds until the total backfill reaches 3 feet (900 mm) over the entire bed.

Call StormTech at **888.892.2694** for technical and product information or visit www.stormtech.com

Table 2 - Maximum Allowable Construction Vehicle Loads⁶

Material Location	Fill Depth over Chambers in. (mm)	Maximum Allowable Wheel Loads		Maximum Allowable Track Loads ⁶		Maximum Allowable Roller Loads
		Max Axle Load for Trucks lbs (kN)	Max Wheel Load for Loaders lbs (kN)	Track Width in. (mm)	Max Ground Pressure psf (kPa)	Max Drum Weight or Dynamic Force lbs (kN)
D Final Fill Material	36" (900) Compacted	32,000 (142)	16,000 (71)	12" (305)	4050 (194)	38,000 (169)
				18" (457)	2760 (132)	
				24" (610)	2130 (102)	
				30" (762)	1770 (84)	
				36" (914)	1530 (73)	
C Initial Fill Material	24" (600) Compacted	32,000 (142)	16,000 (71)	12" (305)	2750 (131)	20,000 (89)
				18" (457)	1920 (92)	
				24" (610)	1520 (73)	
				30" (762)	1310 (63)	
				36" (914)	1180 (56)	
	24" (600) Loose/Dumped	MC-3500		12" (305)	2430 (116)	16,000 (71)
				18" (457)	1730 (82)	
				24" (610)	1390 (66)	
				30" (762)	1210 (58)	
				36" (914)	1100 (52)	
18" (450)	MC-3500		12" (305)	2140 (102)	5,000 (22) (static loads only) ⁵	
			18" (457)	1530 (73)		
			24" (610)	1260 (60)		
			30" (762)	1120 (53)		
			36" (914)	1030 (49)		
B Embedment Stone	12" (300)	Not Allowed	Not Allowed	12" (305)	1100 (53)	Not Allowed
				18" (457)	710 (34)	
				24" (610)	660 (32)	
				30" (762)	580 (28)	
	6" (150)	Not Allowed	Not Allowed	Not Allowed	Not Allowed	Not Allowed

Table 3 - Placement Methods and Descriptions

Material Location	Placement Methods/Restrictions	Wheel Load Restrictions	Track Load Restrictions	Roller Load Restrictions
		See Table 2 for Maximum Construction Loads		
D Final Fill Material	A variety of placement methods may be used. All construction loads must not exceed the maximum limits in Table 2.	36" (900 mm) minimum cover required for dump trucks to dump over chambers.	Dozers to push parallel to rows. ⁴	Roller travel parallel to rows only until 36" (900 mm) compacted cover is reached.
C Initial Fill Material	Excavator positioned off bed recommended. Small excavator allowed over chambers. Small dozer allowed.	Asphalt can be dumped into paver when compacted pavement subbase reaches 24" (600 mm) above top of chambers.	Small LGP track dozers & skid loaders allowed to grade cover stone with at least 12" (300 mm) stone under tracks at all times. Equipment must push parallel to rows at all times.	Use dynamic force of roller only after compacted fill depth reaches 24" (600 mm) over chambers. Roller travel parallel to chamber rows only.
B Embedment Stone	No equipment allowed on bare chambers. Use excavator or stone conveyor positioned off bed or on foundation stone to evenly fill around all chambers to at least the top of chambers.	No wheel loads allowed. Material must be placed outside the limits of the chamber bed.	No tracked equipment is allowed on chambers until a min. 12" (300 mm) cover stone is in place.	No rollers allowed.
A Foundation Stone	No StormTech restrictions. Contractor responsible for any conditions or requirements by others relative to subgrade bearing capacity, dewatering or protection of subgrade.			

